

BY-LAW NUMBER 2004/07

BY-LAW NO. 2004/07 is a by-law of the County of Wetaskiwin No. 10 in the Province of Alberta, respecting the Wetaskiwin Memorial Cemetery operated by the City of Wetaskiwin.

WHEREAS: the Municipal Government Act Chapter M-26 RSA 2000 and amendments thereto and the Cemeteries Act Chapter C-3 RSA 2000 and amendments thereto, provides Council with the authority to regulate and manage Cemeteries, and

WHEREAS: Council has deemed it expedient and necessary to update the Cemetery rules, regulations and tariff of charges to reflect present needs and conditions,

NOW THEREFORE, the Council of the City of Wetaskiwin and the Council of the County of Wetaskiwin duly enacts as follows:

100. **DEFINITIONS**

In this By-law, unless the context otherwise requires:

101. "C.A.O.s" means Chief Administrative Officers (City Manager and County Administrator).
102. "Cairn or Boulder Monuments" refers to a stone or heap of stones placed as a memorial.
103. "Cemetery" means the Wetaskiwin Memorial Cemetery in the City operated by the City under the direction of the Cemetery Committee.
104. "Cemetery Committee" shall consist of three members of the County of Wetaskiwin Council and three members of the City of Wetaskiwin Council.
105. "City" means the City of Wetaskiwin, in the Province of Alberta who operates the Wetaskiwin Memorial Cemetery, which shall include but not be limited to administration, maintenance and record keeping.
106. "County" means the County of Wetaskiwin No. 10.
107. "Cremation Plot" means a single grave lot, measuring 3' x 2' (.9m x .6m).
108. "Grave Liner" means a concrete or metal rough box placed in a grave to house a casket.
109. "Lot" means single grave 4' x 9' (1.2m x 2.7m).
110. "Monument" means any permanent grave structure or headstone level with or above the ground.
111. "Non Resident" means any person who does not reside within the legal limits of the City of Wetaskiwin or the County of Wetaskiwin.
112. "Owner" means a person, heir, executor or authorized funeral director, with burial privileges for one or more lots.
113. "Perpetual Care" means the preservation and maintenance in perpetuity and in a proper manner of the cemetery and grounds.

114. "Perpetual Care Fund" means all funds received by the City from the Perpetual Care fee for the purpose of providing perpetual care and named the Wetaskiwin Memorial Cemetery Perpetual Care Trust Fund.
115. "Unallocated Lots" means a lot prepurchased which will be allocated at the time of burial.
116. "Veteran" means a person who was a member of the Armed Forces of Canada, the United Kingdom or any Armed Forces of a country allied with Canada or the United Kingdom who served in any war.

200. **LAND DESCRIPTION**

The following land is hereby established and set apart for the sole purpose of a public cemetery to be known as:

Wetaskiwin Memorial Cemetery described as follows:

N.E. ¼ 23-46-24-W4M
Lot H
Plan 2758MC
Containing 10.0 acres more or less

300. **GENERAL**

301. The Public Works Superintendent shall have the sole control of all matters within the cemetery that are concerned with maintaining the grounds in a neat and pleasing condition, and to that end, is hereby authorized to regulate and control the cemetery grounds in accordance with Section 700 of this By-law, containing such regulations.
302. No owner shall change the grade of any lot. The Public Works Superintendent is authorized to restore any lot that is altered in grade contrary to the provisions of this section, at the expense of the owner.
303. No person shall make any path, cut any sod, or move or place corner posts or grave markers.
304. Overtime charges will apply for any hours outside the City working hours of 8:30 a.m. to 4:30 p.m. Monday to Friday and Statutory holidays.
305. While the City and County will take all reasonable precautions to protect the property of the owner, it assumes no liability nor responsibility for loss of or damage to any monument, marker or part thereof or any article of any type that may be placed on the lot.
306. The City and County reserves the right to alter regulations set out in Sections 700 of the bylaw and the C.A.O.s may temporarily suspend, revoke or vary any regulation upon a written request.

400. **SALE AND TRANSFER OF LOTS**

401. A person may purchase a maximum of four (4) lots or two (2) cremain plots. Approval by the Cemetery Committee is required for any larger purchases. Upon payment of the fee appearing in Section 900 a deed will be issued.

402. The survey and interment records are maintained by the City at the Public Works Office. The City will accept no responsibility for any excavation upon any lot unless it is undertaken following prior consultation with the Public Works Superintendent.
403. Subdivision J, Blocks 2, 3, 4, and 5 are reserved exclusively for the burial of Veterans of wars in which Canada has participated.
404. The owner of any lot(s) can only sell the lot(s) to the City and the request must be made in writing. The purchase price will be 85% of the current market value. Family members may transfer the lot(s) to each other with a written request to the Public Works Superintendent for approval.
405. For pauper funerals, Social Services rates will apply. All items are GST exempt.

500. **INTERMENTS AND DISINTERMENT**

Any person or agent requesting an interment shall have all related costs as per Section 900 paid for prior to burial or a Request for Cemetery Plot(s) request form turned into the Public Works Superintendent.

501. No person shall personally or by agent undertake an interment in any burial lot unless and until there has been produced to the Public Works Superintendent, the following:
 - (a) Burial Permit issued by the proper official of the Province of Alberta;
 - (b) Cemetery deed issued by the City or written permission from the owner of the said lot permitting the burial, approved by the Public Works Superintendent.
502. A minimum of forty-eight (48) hours notice from May 1 – November 1 and from November 2 – April 30, seventy-two (72) hours notice must be given to the Public Works Superintendent prior to interment, unless otherwise authorized in writing by Public Works Superintendent.
503. Interment of any body other than that of a human being is prohibited.
504. The City and County accept no responsibility for any error or misunderstanding that may arise when any owner or agent orders an interment by telephone.
505. Every owner obtaining a lot in the cemetery shall be held responsible for all charges in connection with the disinterment or removal of a body when applicable.
506. Any person signing an order for interment will be held responsible for all charges in connection with such interment.
507. All persons shall comply with the government regulations for erection of monuments applicable to that part of the cemetery in which the interment is made. The fees for such are set out in Section 900.

508. Disinterments shall only take place at times pre-arranged by the Public Works Superintendent.
509. No disinterments or removal of a body shall be allowed without the consent in writing of the surviving relative or the legal representative of the person whose body is to be disinterred or removed. The City will not be responsible for any disinterments. Disinterments must be arranged and completed by a Funeral Home under the supervision of the Public Works Superintendent. All costs incurred shall be the responsibility of the family or agent, including the cost of a new grave liner if required.
510. Whenever a grave shall become vacant by removal of the body or bodies, the grave from which the body has been removed shall revert without refund to the Wetaskiwin Memorial Cemetery.
511. Disinterment of a body shall not take place until a permit, signed by the Department of Vital Statistics, is presented to the Public Works Superintendent.
512. Concrete grave liners must be used for all burials except for:
 - (a) Children age six (6) and under which require at least a wooden rough box, and
 - (b) Cremains.
513. Concrete grave liners must be totally buried and the highest point being at least two (2) feet (0.6 meter) below the soil surface.
514. All requests for opening and closing graves shall be processed through the Public Works Superintendent. All opening and closing of graves shall be done by the Public Works Superintendent.
515. The Funeral Home shall be responsible for lowering the grave liner, casket and placing and removal of "greens". The Funeral Home or its representative, shall be present until the grave liner is sealed.
516. It is a condition of every deed to use any lot in the Wetaskiwin Memorial Cemetery, that the deed expressly waives any claim arising by reason of any error or misdescription of any burial lot. The City undertakes that it will attempt in so far as is reasonably possible to avoid such errors but its liability shall only extend to refund, in case of error, of any money paid to the City for a lot or lots and it undertakes to make an equivalent quality of lot or lots available in lieu of those originally allocated.
517. All burials are to be made within the confines of a single lot. There shall not be more than one (1) full body burial in a single lot. Ashes, to a total of four cremains, may be buried in an occupied lot when the person in charge of the ashes has received permission for such burial in that lot from the Public Works Superintendent.
518. Except in cases of extreme necessity such as the danger of contagion or infection, or in case of an epidemic, the City will not permit interments to be made on Statutory Holidays, unless by order of the Provincial Board of Health.

519. Before disinterment is allowed for the remains of a person who died from a contagious disease a permit shall be obtained from the Provincial Board of Health and presented to the Public Works Superintendent.
520. All locations of interment shall be determined at the time of burial as per the next available lot. An additional three (3) lots may be purchased and reserved at this time. In such cases when an Organization or Church Group wish to purchase bulk lots, the next available row must be purchased with a minimum of one row (twenty-nine lots per row). Bulk purchases can only be bought in rows. A written request must be submitted to the C.A.O.s for permission towards this purchase.

600. **MONUMENT WORK**

601. No owner may erect upon any lot any monument while any charges in connection therewith are due and owing to the City.
602. No monument, vault or other structure shall be erected or placed on any lot until its design and the plans and specifications relative to the material, construction and the proposed location thereof have been submitted to the City and are in substantial compliance in the opinion of the Public Works Superintendent, with the size, regulations listed in Section 700.
603. No person shall place on any lot a monument of artificial stone, glass, wood, nor of any material not approved in the regulations that are Section 700.
604. Monuments shall only be installed Monday to Friday between 8:30 a.m. and 12:00 noon and 1:00 p.m. and 4:30 p.m. and all work on monument shall cease during a funeral procession and funeral.
605. Cairns or Boulder monuments are not allowed.

700. **REGULATIONS**

701. Advertising

- (a) No person shall canvass for orders or distribute business cards in any cemetery.
- (b) No person shall place upon any monument that is erected in the cemetery the name of the monument dealer or the manufacturer of the name of the quarry or any type of insignia or trademark.

702. Vegetation

- (a) No person shall plant any tree, shrub or herbaceous perennial inside or outside any lot. All permanent planting of trees or shrubs within the cemetery grounds shall be the sole right and duty of the Public Works Superintendent under direction of the Cemetery Committee.
- (b) No person shall tamper with or remove any flowers, plants, trees or shrubs, or monuments located within

the cemetery nor touch any monument nor any fence or other structure belonging to the cemetery.

- (c) All flowers must be placed in a cast bronze or aluminum container. The container must be either affixed to the base or pillow, or have a stainless steel strap bolted to the container so that the strap may be inserted under the base or pillow. No containers shall be attached to the concrete sidewalk. Maximum height from the top of sidewalk to top of container shall be twenty (20) inches
- (d) Cut flowers shall be removed from lots by the cemetery staff as soon as they become wilted or unsightly and persons wishing to retain same must remove them within forty-eight (48) hours after interment.
- (e) Artificial flowers shall be allowed on lots until they become unsightly and/or until they become a significant maintenance problem. Once artificial flowers are removed they will be retained for thirty (30) days so the owner has time to claim them.
- (f) Annual flowers shall not be planted upon graves.

703. **DECORUM**

- (a) No person shall drive a vehicle in a cemetery except at a moderate rate and then only upon the roadway provided for the purpose. No turning or backing is permitted on any roadway on the cemetery grounds.
- (b) No person may picnic, party or gather unless for funerals and related services in the cemetery grounds.
- (c) No person shall disturb the quiet and good order of a cemetery by noise or other improper conduct.
- (d) All lots in the cemetery will be sold with reasonable upkeep. The term reasonable shall mean the regular care as given to all municipal property.
- (e) Visitors must keep to the walks and drives and must not cross over, occupy or otherwise trespass upon any lot or grave not their own.
- (f) All vehicles and funeral processions are subject to the direction and control of the Public Works Superintendent and must not exceed a speed of 15 kilometres per hour while being driven within the cemetery area.
- (g) All persons and their families will be allowed access to the cemetery at proper times. A person may be requested to identify themselves and state their reason for attendance and should that person have no reasonable explanation or have been previously in breach of the cemetery by-law, he or she may be denied access or asked to leave the cemetery.
- (h) No person shall throw rubbish within the cemetery grounds except in the receptacles provided by the City.

704. **ENFORCEMENT**

- (a) Any person who commits an offence pursuant to this By-law is guilty of an offence and is liable on summary conviction to a fine not exceeding ten thousand (\$10,000.00) exclusive of cost, or in the case of non-payment of the fine and cost imposed, to imprisonment for any period not exceeding one (1) year.
705. Any matters not dealt with in this by-law shall be dealt with by the Public Works Superintendent in the manner that they deem most appropriate, having consideration for the appearance of the cemetery and the scope and intent of this by-law.
706. Employees of the City are prohibited from receiving gifts or money. Any employee who accepts any gifts or money is liable for dismissal.
707. **MONUMENT**
- (a) All firms or individuals wishing to place/replace a new monument or memorial must first obtain a permit from Public Works Superintendent at the Public Works Office.
- (b) All monuments must be of granite, marble or bronze.
- (c) All monuments to be rectangular or square.
- (d) No inscription or impression shall be placed on any monument which, in the opinion of the Public Works Superintendent, is not in keeping with the dignity and decorum of the cemetery.
- (e) For the protection of the lot holder and the beauty of the cemetery all inscriptions or impressions on all monuments must be well cut and in good proportion.
- (f) Inscription additions/changes to an existing monument can be made by obtaining a permit.
- (g) In erecting or placing monuments upon any lot or plot the owner or his agent shall conform to the following:
- (i) Be under the supervision of the Public Works Superintendent.
 - (ii) Not interfere with any other lots.
 - (iii) Convey, transport, and place all materials.
 - (iv) Remove all masonry litter, rubbish or refuse from the area and leave it in a neat and tidy condition.
 - (v) In the event of a failure or refusal to do so the City may cause the same to be done and charge the cost thereto to the lot owner or his agent.
- (h) Any monument installed that does not comply with this by-law shall be removed by the Public Works Superintendent and shall only be returned to the owner upon payment of costs as determined by the Public Works Superintendent. (See Appendix A)
- (i) Every owner of a monument or other object upon any lot or plot shall maintain it in proper repair.

- (j) When, in the opinion of the Public Works Superintendent, any monument or other object upon a lot is in a state of disrepair, the owner shall be notified in writing and required to promptly repair the damage. Any monument or erection not repaired within thirty (30) days after a letter has been addressed to the owner or his agent to the last address provided to the City, may be removed from the lot or lots and retained in the custody of the Public Works Superintendent until the person responsible for its maintenance has made arrangements to return it to a suitable condition.

708. **DELEGATION OF AUTHORITY**

- (a) The Public Works Superintendent may delegate their authority to carry out the functions and duties as specified in Section 700, to an outside agency, in accordance with the agreements of the City of Wetaskiwin and County of Wetaskiwin.

800. **PERPETUAL CARE**

801. The Perpetual Care fee must be included in the purchase price of a burial lot.
802. Perpetual Care fee will be charged for each cremains being placed in an already occupied lot and to be paid at the time of opening and closing.
803. The Wetaskiwin Memorial Cemetery Perpetual Care Trust fund shall be established for the future care of the cemetery once the City establishes that the cemetery is full as determined by Cemetery Committee.
804. Interest from the perpetual care fund shall be spent on maintenance of the grounds, buildings, columbarium, fences, vegetation, and may be used to replace vandalized monuments with a flat monument of granite, not exceeding 1 foot x 2 feet (.3m x .6m), that states name and dates if family cannot be contacted at the last know family member address.
805. Tax deductible donations will be accepted and held in the Wetaskiwin Memorial Cemetery Perpetual Care Trust Fund.
806. When lots are sold, reverted or given back to the Wetaskiwin Memorial Cemetery the perpetual care fee shall not be refunded.

900. **FEES**

- (a) Purchase of Lot(s) not including opening and closing charges
- | | | |
|-------|---------------------------------------------|----------|
| (i) | Price per Single Lot | \$500.00 |
| (ii) | Price per Cremains Lot | 250.00 |
| (iii) | Lot for stillborn baby to one year | 500.00 |
| (iv) | Lot for child over one year up to six years | 500.00 |
| (v) | Veteran's Lot | N/C |
| (vi) | Non Resident (for all plots purchased) | 1,000.00 |
- (b) Opening and Closing Charges
- | | | |
|-----|----------------|----------|
| (i) | Standard Grave | \$350.00 |
|-----|----------------|----------|

| | | |
|--------|-------------------------------------------------------------------------------------------------------------|----------|
| (ii) | Grave for stillborn baby to one year | 50.00 |
| (iii) | Grave for child over one year up to six years | 70.00 |
| (iv) | Cremations | 100.00 |
| (v) | Veteran's | 350.00 |
| (c) | Overtime Opening and Closing Charges (Holidays, Saturdays, Sundays and after 4:00 p.m. Monday to Friday) | |
| (vi) | Standard grave | \$600.00 |
| (vii) | Grave for stillborn baby to one year | 125.00 |
| (viii) | Grave for child over one year up to six years | 170.00 |
| (ix) | Cremation | 200.00 |
| (x) | Veteran's | 500.00 |
| (d) | Permits/Charges/Fees | |
| (i) | Replacement or change of an existing monument | N/C |
| (ii) | Monument Permit | \$ 50.00 |
| (iii) | Perpetual Care Fee | 100.00 |
| (iv) | Perpetual Care Fees for Columbarium | 100.00 |
| (v) | Probing Fee (per probe) | 25.00 |

901. GST will be added to all of the above fees

This by-law hereby repeals By-law 98/63 and its amendments and will come into full force and effect on the date of signing.

READ: A First time this 20th day of January, A.D., 2004.

READ: A Second time this 20th day of January, A.D., 2004.

READ: A Third time and finally passed this 20th day of January, A.D., 2004.

APPENDIX "A"
CONDITIONS OF MONUMENT SIZES

All monuments must be placed in accordance with Cemetery By-law No.
 Only monuments meeting the specifications below may be erected in the Wetaskiwin Memorial Cemetery.

PILLOW¹ COMPLETE WITH BASE²
WHETHER DOUBLE OR SINGLE

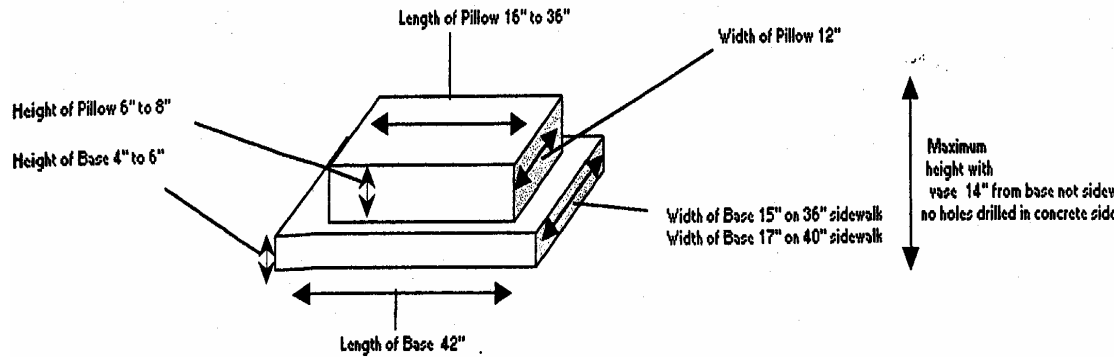

Base Size Minimum & Maximum
Length 42 inches, Width 15 inches on 36" sidewalk and 17" on 40" sidewalk, Height 4 inches to 6 inches

Pillow Size Minimum & Maximum
Length 16 inches to 36", Width 12 inches, Height 6 inches to 8 inches

APPENDIX "A" Continued CONDITIONS OF MONUMENT SIZES

PILLOW ONLY DOUBLE OR SINGLE

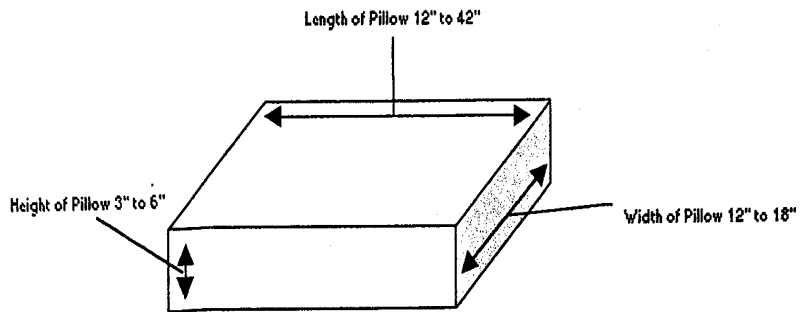

Pillow Size Minimum & Maximum

Length 24 inches to 42 inches,

Width 12 inches to 18 inches,

Height 3 inches to 6 inches

All monuments shall be installed on the concrete sidewalk³ (headstone footing) as shown below.

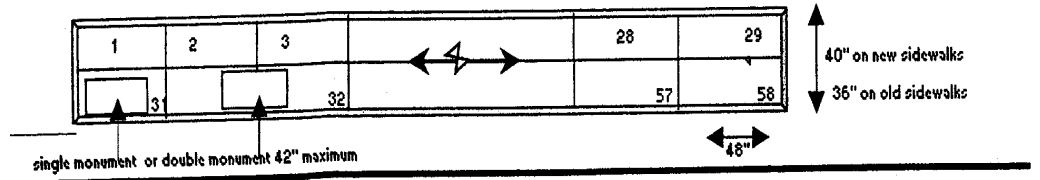

**APPENDIX "A" Continued
CONDITIONS OF MONUMENT SIZES**

All monuments shall be installed on the sidewalk (headstone footing) as shown above.

A monument permit is required.

Monuments shall only be installed between 8:30 a.m. to 12:00 noon and 1:00 p.m. to 4:30 p.m. on City of Wetaskiwin working days.

Any monument that does not comply with this Bylaw shall be removed.

Monument permit fee is \$50.00.

All headstones must be rectangular or square as per history of headstones in the Memorial Cemetery.

-
- 1 A headstone with an inscription that sits on top of the concrete sidewalk (footing) or on top of a base.
 - 2 A riser for the headstone that sits on top of the concrete sidewalk (footing).
 - 3 A concrete footing that all headstones, bases, bases and flowers must be set upon in order to keep the decorum of the cemetery.